



## Touchpoint Plus Wireless Modbus RTU and TCP

## Revision History

Revision	Comment	ECO no.	Date
Issue 01	Initial release	HAA190023	04/2019
Issue 02	add Modbus Registers Function Code 4 Registers - Parent Address, GPS, Man Down / Panic, Portable Monitoring, DIO status Function Code 3 Registers - Sensor Limits, Calibration Date, GPS/Secure Protocol Enable, DIO active modify FC 3 Read Instrument Information (Query Code 121) – add Wireless modem type, Power saving, DIO Enabled, Instrument ID, FW version add FC 3 Read Sensor Information (Query Code 130) - Sensor ID, Unit ID, Measurement Gas ID, Decimal Point, Detection Mode add FC 4 RCM Signal, CfgSet_Cnt	HAA190054	09/2019

## Disclaimer

In no event shall Honeywell be liable for any damages or injury of any nature or kind, no matter how caused, that arise from the use of the equipment referred to in this manual.

Strict compliance with the safety procedures set out and referred to in this manual, and extreme care in the use of the equipment, are essential to avoid or minimise the chance of personal injury or damage to the equipment.

The information, figures, illustrations, tables, specifications, and schematics contained in this manual are believed to be correct and accurate as at the date of publication or revision. However, no representation or warranty with respect to such correctness or accuracy is given or implied and Honeywell will not, under any circumstances, be liable to any person or corporation for any loss or damages incurred in connection with the use of this manual.

The information, figures, illustrations, tables, specifications, and schematics contained in this manual are subject to change without notice.

Unauthorised modifications to the gas detection system or its installation are not permitted, as these may give rise to unacceptable health and safety hazards.

Any software forming part of this equipment should be used only for the purposes for which Honeywell supplied it. The user shall undertake no changes, modifications, conversions, translations into another computer language, or copies (except for a necessary backup copy).

In no event shall Honeywell be liable for any equipment malfunction or damages whatsoever, including (without limitation) incidental, direct, indirect, special, and consequential damages, damages for loss of business profits, business interruption, loss of business information, or other pecuniary loss, resulting from any violation of the above prohibitions.

## Warranty

Honeywell Analytics warrants the Touchpoint Plus Wireless system against defective parts and workmanship, and will repair or (at its discretion) replace any components that are or may become defective under proper usage within 12 months from the date of commissioning by a Honeywell Analytics approved representative\* or 18 months from shipment from Honeywell Analytics, whichever is sooner.

This warranty does not cover consumable, batteries, fuses, normal wear and tear, or damage caused by accident, abuse, improper installation, unauthorized use, modification or repair, ambient environment, poisons, contaminants or abnormal operating conditions.

This warranty does not apply to sensors or components that are covered under separate warranties, or to any 3<sup>rd</sup>-party cables and components.

Any claim under the Honeywell Analytics Product Warranty must be made within the warranty period and as soon as reasonably practicable after a defect is discovered. Please contact your local Honeywell Analytics Service representative to register your claim.

This is a summary. For full warranty terms please refer to the Honeywell Analytics' *General Statement of Limited Product Warranty*, which is available on request.

\* A Honeywell Analytics approved representative is a qualified person trained or employed by Honeywell Analytics, or a qualified person trained in accordance with this manual.

## Copyright Notice

Honeywell is the registered trademark of Honeywell Safety and Productivity Solutions (SPS).

Touchpoint is a registered trademark of Honeywell Analytics (HA).

Find out more at [www.honeywellanalytics.com](http://www.honeywellanalytics.com)

# MODBUS INSTALLATION

## Contents

<b>1</b>	<b>Introduction .....</b>	<b>4</b>
1.1	How to Use this Document.....	4
1.2	Overview .....	4
<b>2</b>	<b>Safety Notices .....</b>	<b>5</b>
<b>3</b>	<b>How to Install the Bus Interface Board (BIB) (Repair, Upgrade or OEM) .....</b>	<b>5</b>
3.1	Modbus RTU Cable .....	7
3.2	Modbus TCP Cable .....	7
3.3	Modbus RTU and TCP Electrical Connections.....	7
3.4	Modbus RTU Chaining / Multi-Drop Mode .....	8
<b>4</b>	<b>How to Configure Modbus RTU / TCP Parameters.....</b>	<b>9</b>
4.1	How to Configure the Master / Host PC .....	9
4.2	How to Configure the TPPLW Modbus RTU Settings .....	9
4.3	How to Configure the TPPLW Ethernet TCP Settings .....	9
<b>5</b>	<b>TPPLW Modbus Register Allocation .....</b>	<b>10</b>
5.1	TPPLW Modbus Register Outline .....	10
5.2	Function 02 – Read Input Status .....	11
5.2.1	Channel Status .....	11
5.2.2	System Summary .....	11
5.3	Function 04 – Read Input Registers .....	12
5.3.1	Signal Level Registers (Integer and Float).....	12
5.3.2	Animation Registers.....	13
5.3.3	Inputs Registers for TPPLW system .....	14
5.3.4	Inputs Registers for TPPLW wireless and RAEMet channel.....	15
5.4	Function 03 / 06 / 16 – Read / Write Holding Registers.....	17
5.4.1	Query Poll Registers .....	17
5.4.2	Command Poll Registers .....	22
5.5	Exception Responses.....	23

# MODBUS INSTALLATION

## 1 Introduction

Modbus is a well-supported digital data communication protocol that provides a set of standard commands by which system data can be communicated.

Touchpoint Plus Wireless (TPPLW) is supplied with Modbus software as a default, but the Modbus Bus Interface Board (BIB, Part Number TPPLORTU) is an optional extra for those customers who want to control TPPLW via Modbus protocols.

Normally the BIB is factory or OEM installed, but it can be fitted or replaced in the field by an authorised Honeywell Field Engineer, or by a qualified person trained in accordance with the TPPLW Technical Handbook and these instructions.

### 1.1 How to Use this Document

This document is provided for the use of Honeywell personnel and Honeywell approved 3<sup>rd</sup>-parties only. Its utilisation requires a high level of computer skill and a competent knowledge of Industrial Gas Detection Systems and Touchpoint Plus Wireless.

Incorrect use of this document or its procedures could result in unexpected and dangerous consequences. Please read the *Disclaimer* and *Warranty* before proceeding.

This document is designed to be a technical reference source that should be used in conjunction with the following documents:

- <http://www.honeywellanalytics.com>. *Touchpoint Plus Wireless Technical Handbook*. (Search for 'Touchpoint Plus Wireless' then click 'Technical Handbook'.)
- [http://modbus.org/docs/PI\\_MBUS\\_300.pdf](http://modbus.org/docs/PI_MBUS_300.pdf). *Modicon Modbus Protocol Reference Guide*. (Check your download folder if the page appears blank.)

This document uses [Button name] and Menu>Item>Command to signify tasks that are carried out on the TPPLW Touchscreen.

### 1.2 Overview

The TPPLW Modbus Interface provides a facility for digital communication between the TPPLW and an external computer system.

Principal features:

- Operates as a Modbus Remote Terminal Unit (RTU) slave device node.
- Operates as a Modbus TCP slave device node.
- Can be used in Modbus Multi-Drop mode.
- Supports functions 02, 03, 04, 06 and 16 of the Modbus protocol.
- Provides sensor gas readings and alarm status for Fault, Inhibit, Warning, A1, A2, A3, STEL, LTEL and Rate alarms from all input channels in the system.
- Supports commands to Inhibit, Reset and Acknowledge for Modbus RTU only.
- Asynchronous serial link configurable for baud, bit-rate and parity.

#### Notes:

- The Modbus broadcast commands are not supported and will be ignored, i.e. it has no output registers at this time.
- There are no standard Modbus function formats defined for the communication of data from a gas detection system so the host computer system must be programmed to interpret the signal and status data made available by TPPLW.
- It is recommended that the host computer system should, as a minimum, be programmed to use Function 02 to collect alarm and status data from all TPPLW channels.
- Full details of the Modbus protocol can be found in the Modicon Modbus Protocol Reference Guide PI-MBUS-300 mentioned above.
- The addressing conventions and register values used follow those set by Modicon. The first digit of the on-board memory address refers to the data type stored in the register and therefore defines the Modbus function command that should be used when polling it.
- Touchpoint Plus Wireless provides compatibility with *Touchpoint Plus (TPPL)* Modbus registers. Therefore, information on input channels 1 to 64 can also be obtained by using the TPPL Modbus registers. This document describes only TPPLW dedicated registers.

## MODBUS INSTALLATION

### 2 Safety Notices

The following safety notices should be read in conjunction with the safety notices and procedures contained in the Touchpoint Plus Wireless Technical Handbook.

#### **DANGER**

TPPLW Safety systems will be inoperative during parts of this procedure. Ensure that a risk assessment is carried out and that alternative safety arrangements are in place before commencing.

#### **WARNING**

The equipment specified in this manual is only to be installed by the Manufacturer's trained personnel, or by competent persons trained in accordance with the Manufacturer's installation instructions.

#### **WARNING**

There is a risk of electric shock when carrying out this procedure. Ensure that the system and backup batteries are electrically isolated and that residual power is allowed to dissipate before opening the enclosure.

#### **WARNING**

If the TPPLW relays are switching mains voltages, hazardous live terminals may be present within the Relay Output Modules even if the TPPLW is electrically isolated.

#### **CAUTION – ELECTROSTATIC HAZARDS**

All electronic and PCB assemblies contain static sensitive components. Take anti-static precautions to minimise the risk of damaging components through electrostatic discharge.

#### **CAUTION**

The SD Card should be removed before attempting to remove the Control Module cover panel.

### 3 How to Install the Bus Interface Board (BIB) (Repair, Upgrade or OEM)

To fit or replace the BIB:

1. Power off and isolate the mains supply and backup batteries and any mains-switching relays.
2. Open the Controller enclosure to access the controller cover panel (see figure on next page.)
3. Remove the three cover securing screws (arrowed).
4. Carefully slide the cover off.

## MODBUS INSTALLATION



Figure 1. Controller Cover Panel Screws (Arrowed)

5. Locate the Bus Interface Board (BIB) position to the right of the MOBO (see picture below).
6. If required, remove the existing BIB by pulling gently, and place it on a static free surface.
7. Observing the correct orientation, align the connectors and gently push the new BIB into place.

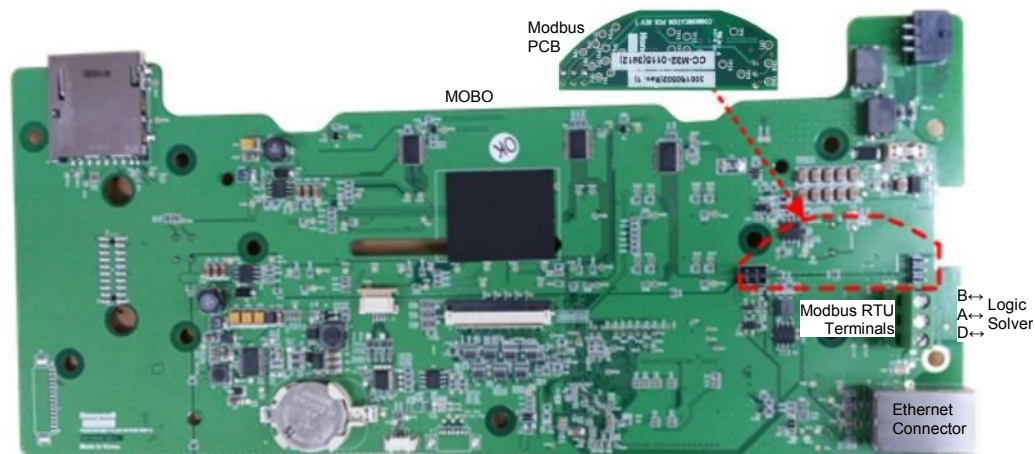

Figure 2. Bus Interface Board (BIB) Fitting

8. Carefully slide the cover back into place and refit / tighten the securing screws.
9. Connect the Modbus cables as shown below.
10. Re-connect all other cables as required.
11. Switch on the batteries and Mains power.
12. Wait for the system to initialize and check / test that everything is working correctly.

## MODBUS INSTALLATION

### 3.1 Modbus RTU Cable

The Modbus RTU cable should be Belden 3105A (22 AWG) or similar shielded data communication cable connected to a router operating at 4800 Baud minimum (>9600 Baud preferred).

### 3.2 Modbus TCP Cable

The Modbus TCP cable should be CAT 5/5E or higher shielded data communication cable suited to the installation distance and ambient environment factors.

In addition:

- Spurs shall not be longer than 1 m each, and shall not exceed 10 m combined total length.
- The maximum cable length without line repeaters is 1.2 km (1200 m, 1300 yd).
- The maximum wire size is 1.5 mm<sup>2</sup> (15 AWG).

### 3.3 Modbus RTU and TCP Electrical Connections

The electrical connections are shown below:

#### CAUTION

Some transceiver manufacturers have been known to incorrectly reverse their RS485 Data terminals, which can cause Tx/Rx to fail. If this happens, simply swap over the TPPLW's A and B cables and then re-test.

MODBUS RTU	Label	Terminal ID	Logic Solver
Drain	D	1	D
Data +	A (D+)	2	A (D+)
Data -	B (D-)	3	B (D-)

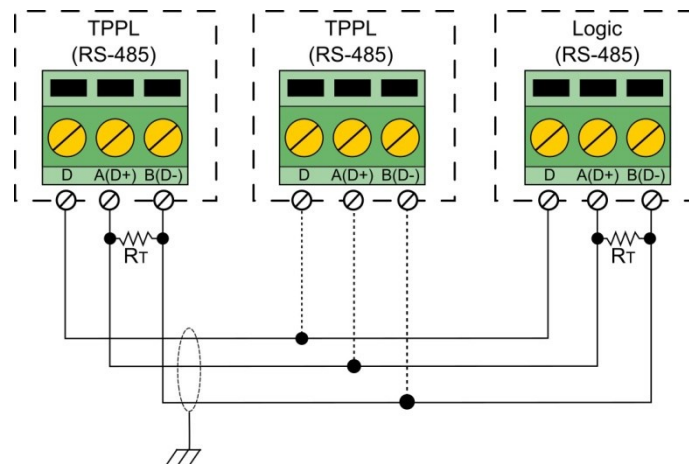

Figure 3. Modbus RTU Connections

**Note:** You should connect a 120Ω termination resistor ( $R_T$ ) between A and B to prevent reflections on the RS485 circuit if TPPLW is the last node in a Modbus system highway.

**Note:** The external  $R_T$  is not needed if the logic solver side has an internal  $R_T$ .



# MODBUS INSTALLATION

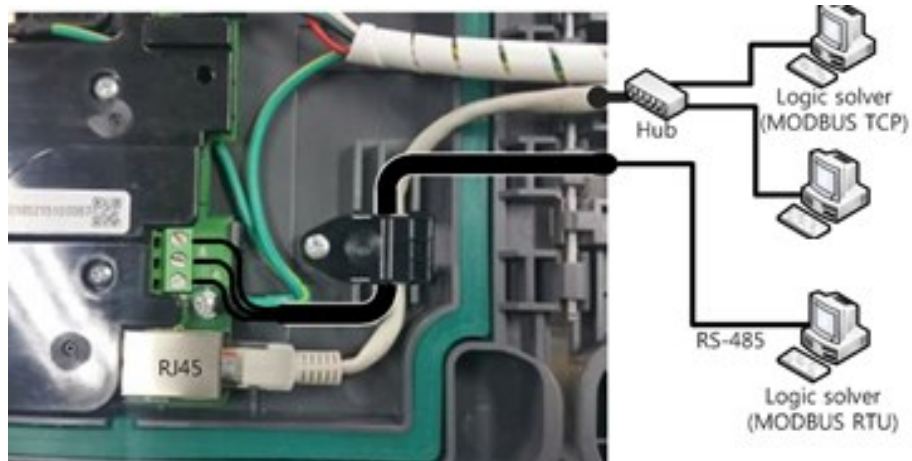

Figure 4. TPPLW Modbus TCP / RTU Client Connections

**Note:** See the use of the cable clamp above.

## 3.4 Modbus RTU Chaining / Multi-Drop Mode

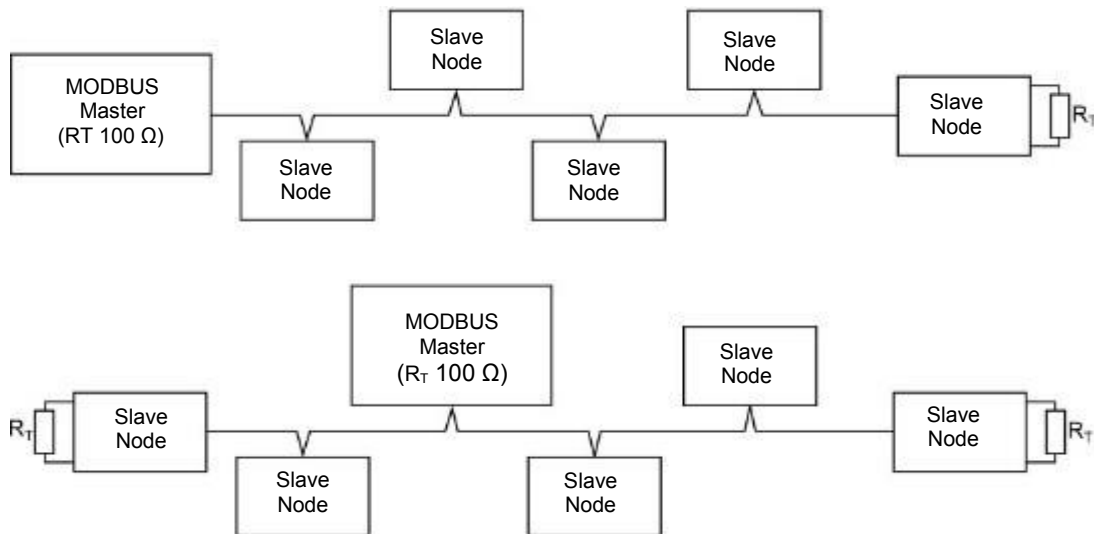

Figure 5. Two Modbus Chaining Examples (other layouts may also be used)

**Note:** TPPLW can be any slave node, and it can support one master node with up to 31 slave nodes when in Multi-Drop Mode.

# MODBUS CONFIGURATION

## 4 How to Configure Modbus RTU / TCP Parameters

### 4.1 How to Configure the Master / Host PC

Before starting, please refer to the documentation supplied with the host computer for details of its communication and Modbus configuration, and to the TPPLW Technical Handbook for details on everything else.

**Note:** It is recommended that the host computer is configured to provide at least two retries in the event of a communication frame loss with a minimum delay of 1 second between each poll, and a minimum timeout of 2 seconds.

### 4.2 How to Configure the TPPLW Modbus RTU Settings

To configure the TPPLW RTU:

1. Login to TPPLW as Administrator or Service.
2. Touch Menu>Configuration>Network>Modbus RTU.
3. Set Slave Address, Baud, Parity and Data bits (see Table 1 below).
4. Touch [Finish].

Parameter Name	Default Setting	Value Range	Comment
Slave Address	1	1 to 247	Each node connected to RS485 highway must have a different address setting
Baud	9600	4800, 9600, 19200	Should be set to correspond to the host network Baud
Parity	None	Even, Odd, None	Should be set to correspond to the parity checking set on the host system
Data bits	8	8	TPPLW Modbus uses 8 data bits and 2 stop bits

Table 1. Modbus Parameter Settings

### 4.3 How to Configure the TPPLW Ethernet TCP Settings

To configure the TPPLW TCP:

1. Login to TPPLW as an Administrator or Service.
2. Touch Menu>Configuration>Network>Ethernet
3. Select [Static IP address] and set the [IP address], [Subnet Mask], [Gateway].
4. Touch [Finish].

# MODBUS CONFIGURATION

## 5 TPPLW Modbus Register Allocation

### 5.1 TPPLW Modbus Register Outline

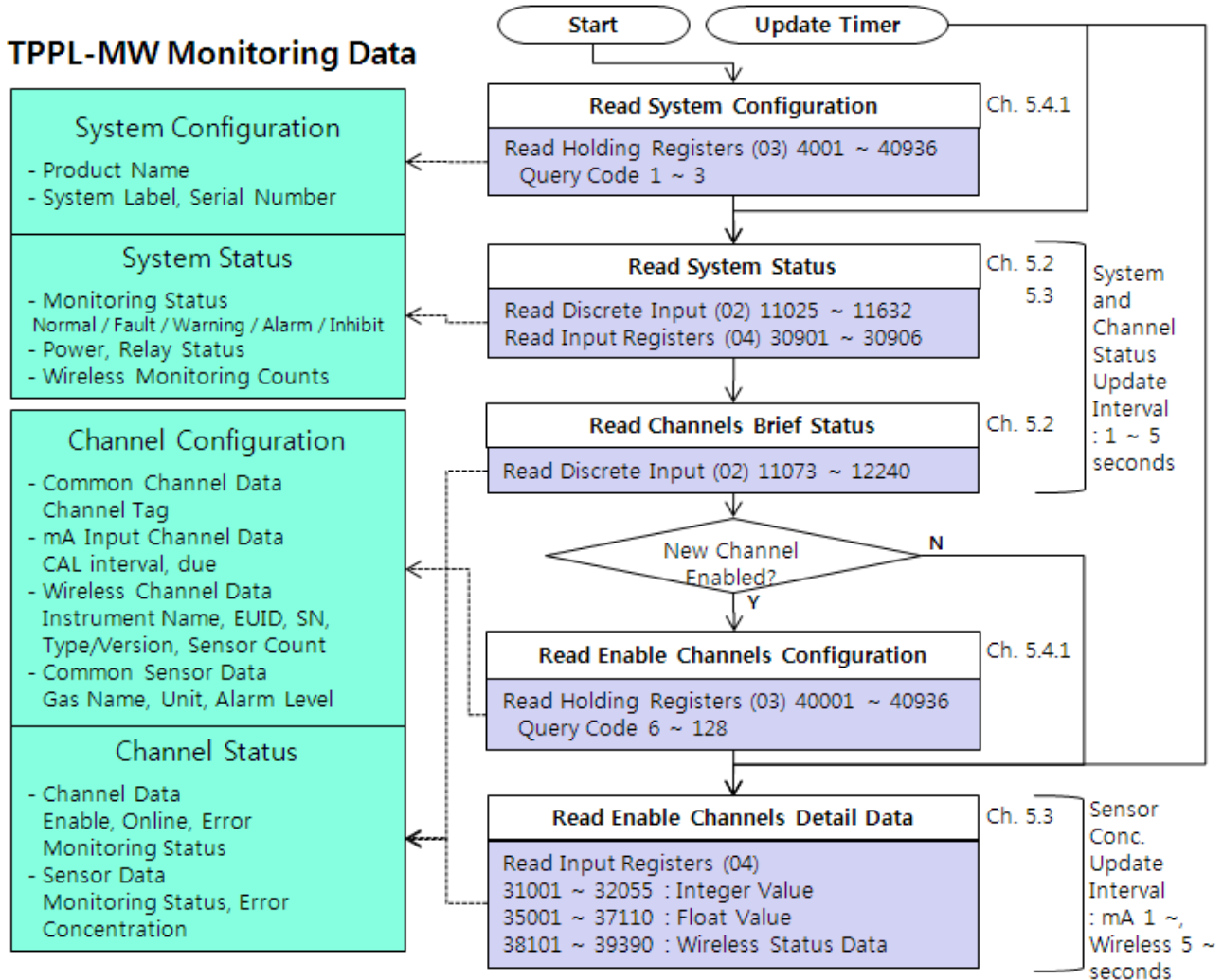

Figure 6. Modbus Register Outline

# MODBUS CONFIGURATION

## 5.2 Function 02 – Read Input Status

This function reads the input channel status bits. Each status bit can have the value 1 = Active or 0 = Not active. For the Channel Type only, 1 = Analogue (mA Input) or 0 = Digital (Wireless or RAEMet). There are 16 status bits for each channel. The maximum number of status bits read in one frame is 608 (<System Summary + 35 channels> or <38 channels>).

### 5.2.1 Channel Status

Channel	Not Used	TWA alarm	STEL alarm	Alarm 3	Alarm 2	Alarm 1	Inhibit	Fault	Not Used	Channel Type	Channel Enable	Channel Online	Not Used	Warning	Acknowledged	Not Used
1 (mA Input)	11073	11074	11075	11076	11077	11078	11079	11080	11081	11082	11083	11084	11085	11086	11087	11088
2 (mA Input)	11089	11090	11091	11092	11093	11094	11095	11096	11097	11098	11099	11100	11101	11102	11103	11104
...																
8 (mA Input)	11185	11186	11187	11188	11189	11190	11191	11192	11193	11194	11195	11196	11197	11198	11199	11200
9 (wireless)	11201	11202	11203	11204	11205	11206	11207	11208	11209	11210	11211	11212	11213	11214	11215	11216
...																
72 (wireless)	12209	12210	12211	12212	12213	12214	12215	12216	12217	12218	12219	12220	12221	12222	12223	12224
73 (RAEMet)	12225	12226	12227	12228	12229	12230	12231	12232	12233	12234	12235	12236	12237	12238	12239	12240

Table 2. Modbus Registers - Channel Status

#### 5.2.1.1 Channel Enable

The Channel Enable field has the value 1 (Active) if the channel is enabled.

Channel enable condition:

mA Input (channel 1 ~ 8): user configured and enables the channel.

Wireless (channel 9 ~ 72): TPPLW detects and retrieves information about the wireless device.

RAEMet (channel 73): user enabled, but TPPLW may not retrieve the RAEMet information if not connected.

The function code 03 (Read Holding Registers) or 04 (Read Input Registers) on the not enabled channel brings failure result or exception.

#### 5.2.1.2 Channel Online

The Channel Online field has the value 1 (Active) if the channel is online (monitoring).

Channel online condition:

mA Input (channel 1 ~ 8): always online.

Wireless (channel 9 ~ 72): TPPLW is receiving data from the wireless device. After a certain time (6 \* Update Duty Cycle) elapses after receiving the last data, it goes offline.

RAEMet (channel 73): TPPLW is receiving data from the RAEMet device. It goes offline if it can't retrieve data from the RAEMet device.

The last collected data is set on the function code 03 or 04 if the channel is offline.

## 5.2.2 System Summary

	Not Used	TWA alarm	STEL alarm	Alarm 3 Summary	Alarm 2 Summary	Alarm 1 Summary	Inhibit Summary	Fault Summary	Not Used	Not Used	Not Used	Not Used	Not Used	Not Used	Not Used	Not Used
System Summary	11025	11026	11027	11028	11029	11030	11031	11032	11033	11034	11035	11036	11037	11038	11039	11040

	Not Used	Not Used	Not Used	Not Used	Not Used	Not Used	Not Used	Not Used	Not Used	Not Used	Not Used	Not Used	Not Used	Not Used	Not Used	Not Used
System Summary	11041	11042	11043	11044	11045	11046	11047	11048	11049	11050	11051	11052	11053	11054	11055	11056

# MODBUS CONFIGURATION

	Not Used	TWA alarm	STEL alarm	Alarm 3 Summary	Alarm 2 Summary	Alarm 1 Summary	Inhibit Summary	Fault Summary	Not Used	Not Used	Not Used	Not Used	Not Used	Not Used	Not Used	Not Used
System Summary	11057	11058	11059	11060	11061	11062	11063	11064	11065	11066	11067	11068	11069	11070	11071	11072

Table 3. Modbus Registers – System Summary

## 5.3 Function 04 – Read Input Registers

There are three sets of input registers for each mA Input channel and Wireless and RAEMet channel sensors:

- The signal level expressed as a 16 bit signed integer value.
- The signal level expressed as a 32 bit floating point value.
- An animation value.

The maximum number of registers that can be requested by function 04 is 64.

### 5.3.1 Signal Level Registers (Integer and Float)

Channel	Sensor Index	Integer Value	Float Value Register 1	Float Value Register 2
1 (mA Input)	-	31001	35001	35002
2 (mA Input)	-	31002	35003	35004
...	...			
8 (mA Input)	-	31008	35015	35016
Channel 9 (Wireless)	1	31009	35017	35018
Channel 9 (Wireless)	2	31010	35019	35020
...				
Channel 9 (Wireless)	16	31024	35047	35048
...				
Channel 72 (Wireless)	1	32017	37033	37034
...				
Channel 72 (Wireless)	16	32032	37063	37064
Channel 73 (RAEMet)	1	32033	37065	37066
...				

Table 4. Modbus Registers - Signal Level

**Note:** The Integer Value format is a 16 bit signed integer, range -10000 to +10000 in steps of 0.1 % FSD - e.g., if FSD is 500 and the reading is 50, then the data will be 100 (10.0 % FSD) – if the channel is mA Input or wireless detector.

**Note:** The Float Value format is a 32 bit floating point value in accordance with IEEE 754-2008 if the channel is mA Input or wireless detector.

**Note:** The Integer Value format is an unsigned 16 bitmask if the channel is wireless relay. Bit 0 (LSB) is 1 if the first relay is activated. Bit 1 ~ 4 is 1 if the second ~ fifth relay is activated. The Float Value on the wireless relay channel is float-casted of the integer value.

# MODBUS CONFIGURATION

## 5.3.2 Animation Registers

These Animation Registers are intended to be used by graphics packages for defining the colours of various screen objects based upon the status of a channel.

A 16 bit unsigned word format is used.

Channel	Sensor Index	Animation Value
1 (mA Input)	-	33001
2 (mA Input)	-	33002
...	...	
8 (mA Input)	-	33008
Channel 9 (Wireless)	1	33009
Channel 9 (Wireless)	2	33010
...		
Channel 9 (Wireless)	16	33024
...		
Channel 72 (Wireless)	1	34017
...		
Channel 72 (Wireless)	16	34032
Channel 73 (RAEMet)	1	34033
...		

Table 5. Modbus Registers - Channel Animation

The data value for each register can be assigned to one of the following:

Status	Value
Channel operating normally	0
RATE alarm active	1
TWA alarm active	2
STEL alarm active	3
A1 alarm active	4
A2 alarm active	5
A3 alarm active	6
Fault active	7
Inhibit active	8
Warning	9
Simulation	10
No data available - not enable channel	11
No data available - not enable channel	255

Table 6. Modbus Channel Animation Values

# MODBUS CONFIGURATION

## 5.3.3 Inputs Registers for TPPLW system

Data	Register	Remark
System Error	30901	Fault Code
TPPLW Power	30902	High byte for status: High byte for status: 1: AC, 2: DC, 3: AC+DC Low byte for percentage
Monitor available	30903	High byte for Online Monitoring Status (the monitor's data availability): 0: unavailable, 1: available Low byte for Count of Online Node: the number of online monitors in the controller
Online Monitor Setting Count	30904	Online Monitoring value set by user, that is used as threshold to make fault
Analog Relay Status - Main Module	30905	u16, bit 0 (LSB): system, bit 1: relay 1, bit 2: relay 2
Analog Relay Status - Relay Module 1	30906	u16, bit 0 (LSB): relay 1 ~ bit 11: relay 12
TPPLW setting	30907	System setting. 16bit unsigned Integer. bit 0 (LSB) : Enable Online monitoring Portable Devices. 1 - the online monitoring is applied to all the wireless channel. 0 - exclude portable wireless device

Table 7. Modbus Registers – TPPLW System Status

### 5.3.3.1 System Error (Fault Code)

Fault	Code	Fault	Code
INTERNAL COMMUNICATION FAILURE	1	RELAY NOT CONTROLLED	11
INTERNAL MEMORY FAILURE	2	REMOTE FAULT INFORMED BY DETECTOR	12
CATALOG MEMORY CORRUPTED	3	AUXILIARY BATTERY FAULT	13
INTERNAL HARDWARE FAILURE	4	IO BOARD NOT MATCHED OR PRESENT	14
SENSOR CIRCUIT FAILURE	5	IO CELL NEGATIVE READING	15
SUPPLIED VOLTAGE FAILURE	6	WIRELESS NODE FAULT	18
INTERNAL SOFTWARE FAILURE	7	ONLINE MONITOR FAULT	19
MODBUS COMMUNICATION FAILURE	8	WIRELESS NODE BATTERY LOW	20
SENSOR FAILURE	9	WIRELESS NODE SENSOR FAULT	21
ANALOGUE OUTPUT MISMATCHED FAILURE	10	WIRELES SENSOR NEGATIVE READING	22

Table 8. Modbus System Fault Codes

# MODBUS CONFIGURATION

## 5.3.4 Inputs Registers for TPPLW wireless and RAEMet channel

Channel	Device Error	Device Power	Sensor Error 1,2	Sensor Error 3,4	Sensor Error 5,6	Sensor Error 7,8	Sensor Error 9,10	Sensor Error 11,12	Sensor Error 13,14	Sensor Error 15,16	Reserved
9	38101	38102	38103	38104	38105	38106	38107	38108	38109	38110	38111 ~381120
10	38121	38122	38123	38124	38125	38126	38127	38128	38129	38130	
...	...	...	...	...	...	...	...	...	...	...	...
73 (RAEMet)	39381	39382	39383	39384	39385	39386	39387	39388	39389	39390	

Channel	Parent Address	GPS x Float Value register1	GPS x Float Value register2	GPS y Float Value register1	GPS y Float Value register2	DIO Status	RCM Signal	CfgSet_Cnt
9	38111	38112	38113	38114	38115	38116	38117	38118
10	38131	38132	38133	38134	38135	38136	38137	38137
...	...	...	...	...	...	...	...	...

Table 9. Modbus Registers – TPPLW Wireless and RAEMet Status

**Note:** Each wireless and RAEMet channel - number n - features 20 registers starting from <math>38101 + (n-9) \* 20</math>. RAEMet channel (number 73) features register range of 39381 ~ 39390.

Data name	Details
Device Error, Alarm	Bit 0 (LSB) not used Bit 1 Battery : 1=Low, 0= Normal Bit 2 Pump : 1=Stall, 0=Normal or not installed Bit 3 Memory : 1=Full, 0=Normal or not installed Bit 4 Sensor mask = sensor alarm flag Bit 5 Unit Failure : 1=Failure, 0=OK Bit 6 ~ 7 : not used Bit 8 ~ 9 Man Down Status : 1=man down warning, 2=man down alarm, 3=super alarm Bit 10 Panic Alarm : 1=Panic Alarm is activated Bit 11 ~ 15 (MSB) : not used
Device Power	High byte for status: 0: Battery only, 1: charging, 2: fully charged+AC, 3: AC only or external battery. Low byte for percentage.
Sensor Error 1,2	High byte for sensor index 1, Low byte for sensor index 2. The format of the error byte is determined by Device Protocol Version.
Sensor Error 3,4	High byte for sensor index 3, Low byte for sensor index 4.
Parent Address	Parent Device Address
GPS Float Value	GPS x and y position. The format is same with Channel n Float Value.
DIO Status	Digital Input and Output Status. Bit 0 (channel 0) ~ Bit 15 (channel 15). Digital Input Status == DIO Status BITWISE_AND <Digital Input Active mask> Digital Output Status == DIO Status BITWISE_AND <Digital Output Active mask>



# MODBUS CONFIGURATION

## 5.3.4.1 Sensor Error Code for Protocol Version 1

Bit Name	Bit Position	Remarks
Over Range	0 (LSB) (0x01)	1=fail, 0=normal
MAX	1 (0x02)	1=fail, 0=normal
Sensor Failure	2 (0x04)	1=fail, 0=normal
High limit	3 (0x08)	1=fail, 0=normal
Low limit	4 (0x10)	1=fail, 0=normal
STEL limit	5 (0x20)	1=fail, 0=normal
TWA limit	6 (0x40)	1=fail, 0=normal
Drift	7 (MSB) (0x80)	1=fail, 0=normal

Table 10. Modbus Sensor Error Code for Protocol Version 1

## 5.3.4.2 Sensor Error Code for Protocol Version 2

Error Name	Value	Remarks
OK	0x00 (0)	No error
CAL	0x01 (1)	Calibration fail
Cal Due	0x02 (2)	Calibration out-of-date
Bump	0x03 (3)	Bump Fail
Bump Due	0x04 (4)	Bump test out-of-date
Lamp	0x20 (32)	PID sensor: Lamp Fail
Off	0x21 (33)	LEL sensor: Sensor Off
Short	0x22 (34)	LEL sensor: Short circuit
Broken	0x23 (35)	LEL sensor: broken circuit
Fail	0x3F (63)	Undefined (or other) sensor HW fail.
MAX	0x40 (64)	ADC saturated
OVR	0x41 (65)	OverRange
HighHigh	0x42 (66)	Extremely-High
High	0x43 (67)	High Limit
Low	0x44 (68)	Low Limit
LowLow	0x45 (69)	Extremely-Low
STEL	0x46 (70)	
TWA	0x47 (71)	
NEG	0x48 (72)	Negative
Dose	0x49 (73)	Radiation Sensor
Alarm	0x5F (95)	Undefined other sensor (application) alarm.

Table 11. Modbus Sensor Error Code for Protocol Version 2

# MODBUS CONFIGURATION

## 5.4 Function 03 / 06 / 16 – Read / Write Holding Registers

All registers use 16 bit data words.

Function 06 and 16 can be used to write to the 40n01 to 40n04 (n = 0 to 9) ranges of registers only.

The maximum number of registers that can be requested by function 03 and 16 is 36 for the Query poll block or 6 for the Command poll block. Query Poll Registers.

TPPLW can monitor max. 8 mA Inputs and 1024 Wireless Sensors (64 channels multiplied by 16 sensors. Allocate 16 sensors per channel, use 12 sensors at a moment) and 4 RAEMet Sensors. The register address range is not sufficient to provide direct access the sensor information. Therefore TPPLW provides indirect access method by using Poll Register.

### 5.4.1 Query Poll Registers

Query Poll Block	Block Active (Write)	Channel Type (Write)	Channel ID (Write)	Query Code (Write)	Result (Read)	Response Data (Read)
1	40001	40002	40003	40004	40005	40006 to 40036
2	40101	40102	40103	40104	40105	40106 to 40136
3	40201	40202	40203	40204	40205	40206 to 40236
4	40301	40302	40303	40304	40305	40306 to 40336
5	40401	40402	40403	40404	40405	40406 to 40436
6	40501	40502	40503	40504	40505	40506 to 40536
7	40601	40602	40603	40604	40605	40606 to 40636
8	40701	40702	40703	40704	40705	40706 to 40736
9	40801	40802	40803	40804	40805	40806 to 40836
10	40901	40902	40903	40904	40905	40906 to 40936

Table 12. Modbus Registers - Query Poll

#### 5.4.1.1 Block Active (Write)

If 'Block Active' is set to 1, the Controller processes the request, but if 'Block Active' is set to 0 the Controller will not process the request or has already processed the request.

The Block Active register is used to request starting the query or poll operation, or to get the operation status.

- Write command: If Block Active is set to 1, the controller does process the operation.

- Read command: If Block Active value is 1, the operation was not completed yet, re-read until the register is set to 0. If Block Active value is 0, the controller already processed the operation and the result registers have result.

However, TPPLW sets the register always 0 – operation is finished – after writing 1, so the Modbus client doesn't need to re-read the Block Active register to check if the operation is finished or not.

### CAUTION

When using Function 6 or Function 16, ensure that the registers related to the command are completely filled before setting the Block Active register, otherwise an unintended command may be performed.

#### 5.4.1.2 Channel Type (Write)

The Channel Type field identifies the channel as Input or Output. The decimal value 105 (= ASCII "i") is used for Inputs, the decimal value 111 (= ASCII "o") for Outputs.

TPPL and TPPLW support Poll Registers for Input Channels.

# MODBUS CONFIGURATION

### 5.4.1.3 Channel ID (Write)

The Channel ID register is used to set the channel number (Low byte) and sensor index (High byte). The sensor index can be set to 1 ~ <Sensor Count>. Set the index to 0 on the mA Input channel (1~8) since the mA Input channel only has one sensor. The <Sensor Count> can be retrieved from Query poll "Read Sensor Count" on the wireless (9~72) or RAEMet (73) channels.

Channel ID example:

- 0x0001: channel 1 - mA Input, the sensor index (high byte, 0x00) is not used
- 0x0109: channel 9 - the first wireless channel, the sensor index is 1 (first sensor)
- 0x0009: channel 9 - the sensor index 0 is treated as 1, so 0x0009 has the same meaning with the 0x0109
- 0x0249: channel 73 - the RAEMet channel, sensor index 2 (second sensor)

### 5.4.1.4 Result (Read)

The Result register is set as operation result (success or fail) after a query or command operation is completed.

Allowed values for the Result register 40n05 (n = 0 to 9):

Result	Meaning
0	Success
1	Query Code or Command Code not permitted
2	Inter process communication failure
67	Failure (invalid / disabled channel number or sensor index)

Table 13. Modbus Query Poll Result Register Values

### 5.4.1.5 Response Data (Read)

The Response Data Register is set as operation result data after a query operation is completed.

# MODBUS CONFIGURATION

## 5.4.1.6 Query Codes (Write)

Query Code	Description	Response Data Format	Information Type
1	Read serial number	Unicode String – 35 (Unicode chars) + 1(null)	system
2	Read System Label	Unicode String – 35 (Unicode chars) + 1(null)	system
3	Read System Product Name	constant Unicode String, "Touchpoint Plus Mesh Wireless"	system
6	Read range full scale	Float (4 Bytes – 32 bit floating point)	mA Input or Wireless sensor
7	Read range zero scale	Float (4 Bytes – 32 bit floating point)	mA Input
39	Read Alarm 1 level (Low)	Float (4 Bytes – 32 bit floating point)	mA Input or Wireless sensor
40	Read Alarm 2 level(High)	Float (4 Bytes – 32 bit floating point)	mA Input or Wireless sensor
41	Read Alarm 3 level (HighHigh)	Float (4 Bytes – 32 bit floating point)	mA Input or Wireless sensor
42	Read STEL level	Float (4 Bytes – 32 bit floating point)	Wireless sensor
43	Read LTEL level	Float (4 Bytes – 32 bit floating point)	always 0 on TPPL and TPPLW
44	Read Rate level	Float (4 Bytes – 32 bit floating point)	always 0 on TPPL and TPPLW
102	Read Gas Name	Unicode String – 35 (Unicode chars) + 1(null)	mA Input or Wireless sensor
103	Read Channel Tag Name	Unicode String – 35 (Unicode chars) + 1(null)	input channel
104	Read Gas Unit	Unicode String – 35 (Unicode chars) + 1(null)	mA Input or Wireless sensor
105	Read peak reading	Float (4 Bytes – 32 bit floating point)	mA Input channel
106	Read calibration interval	16bit signed Integer	mA Input channel
107	Read calibration due	16bit signed Integer	mA Input channel
121	Read Instrument Information	16bit Unsigned Integer array Word [0] bit 0 (LSB) : 0 - Detector, 1 - Wireless Relay bit 1 : 1 - GPS enable, 0 - GPS none bit 2 : 1 - Secure Protocol is used bit 3 : Wireless modem runtime type. 1: FFD, 0: RFD bit 4 : Power saving. 0: the communication channel is always available, 1: the remote unit will enter power saving mode after send packets. bit 5 : DIO Enabled. 1: DIO Enabled, 0: DIO Disabled or not supported bit 6 ~ 15 (MSB) : Reserved Word [1] - Instrument ID. Family_ID (High Byte) model_ID (Low Byte) Word [2] - Instrument ID. HW_ID (High Byte) FW_ID (Low Byte) Word [3] ~ [5] - FW version (6 Bytes)	wireless and RAEMet channel
122	Read Instrument Name of the Device	Unicode String – 20 (Unicode chars) + 1(null)	wireless and RAEMet channel
123	Read Device Serial Number	Unicode String – 12 (Unicode chars) + 1(null)	wireless and RAEMet channel
124	Read Device EUID	16bit unsigned Integer. Wireless node's EUID (last 2byte)	wireless channel
125	Read Device Protocol Version	16bit unsigned Integer. 1 or 2. used to decode sensor error registers.	wireless and RAEMet channel

# MODBUS CONFIGURATION

126	Read Sensor or Relay Count	16bit unsigned Integer. The number of enabled sensors on the Device. Max 12. (if the instrument is wireless relay, relay instead sensor)	wireless and RAEMet channel
127	Read Enabled Sensor or Relay Mask	16bit unsigned Integer. each bit denotes whether the logical sensor socket is enabled or not : 1- enabled, 0- disabled, or no sensor, or no such socket. bit 0 (LSB) : first sensor socket, ... bit 15 (MSB) : last sensor socket (if the instrument is wireless relay, relay instead sensor)	wireless and RAEMet channel
128	Reading Update Duty Cycle (Interval )	16bit unsigned Integer.	wireless and RAEMet channel
129	Read DIO Active Mask	array of the 16bit unsigned Integer. Bit 0 (channel 0) ~ Bit 15 (channel 15). Word [0] - Digital Input Active mask. Word [1] - Digital Output Active mask.	wireless channel
130	Read Sensor Information	16bit Unsigned Integer array Word [0] - Sensor ID Word [1] - Unit ID Word [2] - Measurement Gas ID Word [3] - Decimal Point Word [4] - Detection Mode	wireless sensor
131	Read Sensor Limit - LowLow	Float (4 Bytes – 32 bit floating point)	wireless sensor
132	Read Sensor Limit - OverRange	Float (4 Bytes – 32 bit floating point)	wireless sensor
133	Read Sensor Limit - STEL	Float (4 Bytes – 32 bit floating point)	wireless sensor
134	Read Sensor Limit - TWA	Float (4 Bytes – 32 bit floating point)	wireless sensor

Table 14. Modbus Query Codes

### 5.4.1.7 Query Poll Register Example

Query Poll Example: Read Alarm 1 level of the mA Input channel 2

Register	Block Active (40n01)	Channel Type (40n02)	Channel ID (40n03)	Query Code (40n04)	Result (40n05)	Response Data (40n06 to 40n36)
Value	1	105 (0x69)	0x0002	39 (0x27)	(Updated upon request execution)	(Updated upon request execution)

Table 15. Modbus Query Poll Example

#### Scenario to read the Alarm 1 level of the mA Input channel 2:

**Step 1:** set register to read the data and to request running the query. Write to the 40001 ~ 40004 registers: 0x0001 0x0069 0x0002 0x0027

**Step 2:** retrieve data. Read from the 40005 ~ 400036 registers. Use the 40006 ~ 40036 registers (Response Data) if the 40005 register (Result) value is 0 (success).

# MODBUS CONFIGURATION

## 5.4.1.8 Query Poll Register Processing Procedure

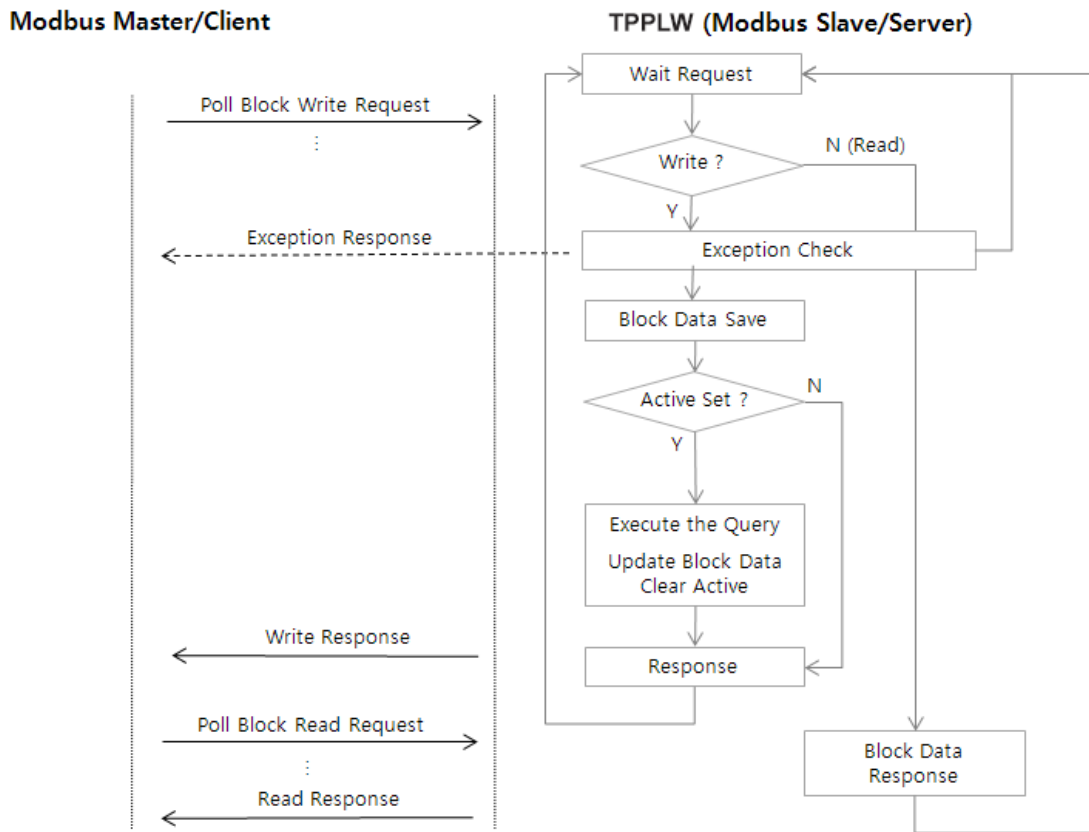

Figure 7. Modbus Query Poll Register processing procedure

# MODBUS CONFIGURATION

## 5.4.2 Command Poll Registers

### CAUTION

The Command Poll Registers can be accessed by only Modbus RTU while the TPPLW is not login as Service or Administrator.

The Block Active, Channel Type, Channel ID, Result registers have the same function with Query Poll Registers.

The sole option for Channel Type is 105 – Input Channel.

**Note:** The Command is permitted only when login on Service or Administrator on the TPPLW.

Command Poll Block	Block Active (Write)	Channel Type (Write)	Channel ID (Write)	Command Code (Write)	Command Data (Write)	Result (Read)
1	41001	41002	41003	41004	41005	41006
2	41101	41102	41103	41104	41105	41106
3	41201	41202	41203	41204	41205	41206
4	41301	41302	41303	41304	41305	41306
5	41401	41402	41403	41404	41405	41406
6	41501	41502	41503	41504	41505	41506
7	41601	41602	41603	41604	41605	41606
8	41701	41702	41703	41704	41705	41706
9	41801	41802	41803	41804	41805	41806
10	41901	41902	41903	41904	41905	41906

Table 16. Modbus Registers - RTU Command Poll

### 5.4.2.1 Command Code (Write)

Command Code	Description	Remarks
23	Alarm Acknowledge for all channel	The commands apply to all channels. The Channel Type and Channel ID register values are not used on this command.
24	Alarm Reset for all channel	
25	Set Inhibit (analog only: ch1~8)	The Channel Type must be set as input ('i' 105). The Channel ID must be mA Input Channel.
26	Clear inhibit (analog only: ch1~8)	

Table 17. Modbus RTU Command Codes

### 5.4.2.2 Command Data (Write)

Command Data is not utilized at the moment.

# MODBUS CONFIGURATION

### 5.4.2.3 Example

Example: Alarm Acknowledge (Command Code):

Register	Block Active (41n01)	Channel Type (41n02)	Channel ID (41n03)	Command Code (41n04)	Command Data (41n05)	Result (41n06)
Value	1	105	2	23	0	(Updated upon request execution)

Table 18. Command Code Example

## 5.5 Exception Responses

The Modbus exception response is detailed in the *Modicon Modbus Protocol Reference Guide*. Any one of the following exception responses may be returned by the Touchpoint Plus Wireless Modbus interface:

Exception	Description
01 ILLEGAL FUNCTION	Only Modbus functions 02, 03, 04, 06, 16 are supported. This response is returned if any other requests are received.
02 ILLEGAL DATA ADDRESS	The register addresses supported by each function are listed in this chapter. Any attempt to access a register outside of these ranges will result in this error.
03 ILLEGAL DATA VALUE	This exception is returned if the request has the incorrect length, or if the maximum number of registers is exceeded. The maximum number of registers that can be requested by function 02 is 608, function 04 is 64, and function 03 is 36 for the Query poll block or 6 for the Command poll block.
06 SLAVE DEVICE BUSY	Applies to function 06 only. Once a poll or command block's active register has been set, its contents must not be changed until the main program has carried out the request. This exception is returned if any attempt is made to change an active poll or command block.

Table 19. Modbus Exception Responses



Find out more at  
[www.honeywellanalytics.com](http://www.honeywellanalytics.com)

**Contact Honeywell Analytics:**

**Europe, Middle East, Africa**

Life Safety Distribution GmbH  
Javastrasse 2  
8604 Hegnau  
Switzerland  
Tel: +41 (0)44 943 4300  
Fax: +41 (0)44 943 4398  
[gasdetection@honeywell.com](mailto:gasdetection@honeywell.com)

**Customer Service:**

Tel: 00800 333 222 44 (Freephone number)  
Tel: +41 44 943 4380 (Alternative number)  
Fax: 00800 333 222 55  
Middle East Tel: +971 4 450 5800 (Fixed Gas Detection)  
Middle East Tel: +971 4 450 5852 (Portable Gas Detection)

**Americas**

Honeywell Analytics Inc.  
405 Barclay Blvd.  
Lincolnshire, IL 60069  
USA  
Tel: +1 847 955 8200  
Toll free: +1 800 538 0363  
Fax: +1 847 955 8210  
[detectgas@honeywell.com](mailto:detectgas@honeywell.com)

**Asia Pacific**

Honeywell Analytics Asia Pacific  
7F SangAm IT Tower,  
434 Worldcup Buk-ro, Mapo-gu,  
Seoul 03922, Zuid-Korea  
Korea  
Tel: +82 (0)2 6909 0300  
Fax: +82 (0)2 2025 0328  
India Tel: +91 124 4752700  
[analytics.ap@honeywell.com](mailto:analytics.ap@honeywell.com)

**Technical Services**

EMEA: [HAexpert@honeywell.com](mailto:HAexpert@honeywell.com)  
US: [ha.us.service@honeywell.com](mailto:ha.us.service@honeywell.com)  
AP: [ha.ap.service@honeywell.com](mailto:ha.ap.service@honeywell.com)

[www.honeywell.com](http://www.honeywell.com)

**Please Note:**

While every effort has been made to ensure accuracy in this publication, no responsibility can be accepted for errors or omissions. Data may change as well as legislation and you are strongly advised to obtain copies of the most recently issued regulations, standards and guidelines. This publication is not intended to form the basis of a contract.

**Honeywell**